

To: Paul Starer, Dean, Language Arts
From: Mallory Newell, De Anza Researcher
Date: 9/7/2011
Subject: English 100 Course Sequence 2009-10 to 2010-11

Re:

Students who successfully passed English 100 in fall 2009 or fall 2010 were tracked through the subsequent winter and spring to determine whether they enrolled in English 110, English 1A, English 1B, English 1C or ESL 25 or ESL 26. Success rates in the subsequent courses were provided.

Annual success rates for all students in each course were also provided.

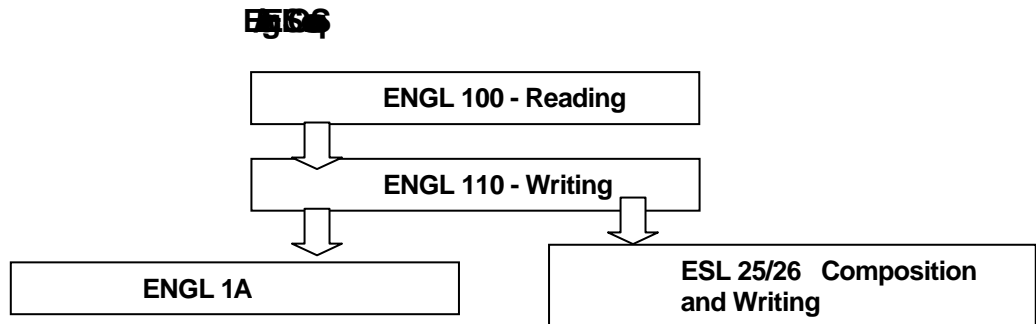

1.

2009-10

In fall 2009, 303 students passed ENGL 100 and enrolled in a subsequent English course in 2010W or 2010S.

The overall success rate for the students that were successful in ENGL 100 in fall 2009 who enrolled in a subsequent English course was 78%.

Students that enrolled in ENGL 110 had a success rate of 75%, students that enrolled in ENGL 1A had a success rate of 82%, and students that enrolled in ENGL 1B or higher had a success rate of 77%.

2010-11

In fall 2010, 330 students passed ENGL 100 and enrolled in a subsequent English course in 2011W or 2011S.

The overall success rate for students that were successful in ENGL 100 in fall 2010 who enrolled in a subsequent English course was 80%.

Students that enrolled in ENGL 110 had a success rate of 77%, students enrolled in ENGL 1A had a success rate of 82% and students that enrolled in ENGL 1B or higher had a success rate of 100%.

2. **EN 100**

2009-10

112 (30%) students were not successful in ENGL 100 in fall 2009 out of 381 students enrolled in the course. 46% of the students that did not pass ENGL 100 enrolled in another course in 2010W or 2011S.

Of those students, 19 enrolled in ENGL 205, 1 in ENGL 100 in 2010W. In 2010S, 12 enrolled in ENGL 100, 7 in ENGL 110, and 1 in ENGL 215.

Success rates for these students in subsequent English courses were lower for these students than students who passed ENGL 100 in 2009F.

2010-11

119 (33%) students were not successful in ENGL 100 in fall 2010 out of 361 students that enrolled in the course. 63 (53%) of the students that did not pass ENGL 100 enrolled in another English course in 2011W or 2011S.

Of those students, 1 enrolled in ENGL 205, 2 in ENGL 110, 26 in ENGL 100, 1 in ENGL 12 in 2011W. In 2011S, 27 enrolled in ENGL 209, 5 in ENGL 110, and 1 in ENGL 31.

Success rates for these students in subsequent English courses were again lower for these students than students who passed ENGL 100 in the 2010F.

3. **EN 110**

2009-10

Of the students that passed ENGL 100 in fall 2009, 35% enrolled directly into ENGL 1A. 60% of the students enrolled into ENGL 110 and 4% enrolled in ENGL 1B or higher.

2010-11

Of the students that passed ENGL 100 in fall 2010, 39% enrolled directly into ENGL 1A. 58% of the students enrolled into ENGL 110 and 3% enrolled in ENGL 1B or higher.

4. **EN 110**

The trends in course sequence patterns have remained rather consistent between 2009-10 and 2010-11.

EN 110

Success rates for ENGL 100 between 2009-10 and 2010-11 remained rather stable between 67% and 66%.

Success rates for ENGL 110 remained stable at 70% to 71%.

Success rates for ENGL 1A increased from 74% to 76% while success rates in ENGL 1B remained the same at 80%, and success rates for ENGL 1C decreased from 89% to 71% from year-to-year.

Success rates for ESL 25 increased from 87% to 91%. ESL 26 success rates also increased from 83% to 86%.

Success in Subsequent Course Following ENGL 100 - Row Percent

[REDACTED]		Non Success		Withdraw		Total	
Grades	Percent	Grades	Percent	Grades	Percent	Grades	Percent

Students who passed English 100 in fall 2009, the course they took following ENGL 100 in winter or spring 2010 and their success in that course (ENGL 110, ENGL 1A, 1B, 1C, or ESL 25/26). Only the first course they took in the series was included.

Success in Subsequent Course Following ENGL 100 - Column Percent

Students who did not pass English 100 in 2009F who took another English course in 2010W or 2010S

Success		Non Success	Withdraw	Total
Grades				

Note: Success = A, B, C, P; Non Success = D, F, NP, I; Withdraw = W

Note: Success = A, B, C, P; Non Success = D, F, NP, I; Withdrawal = W

Success Rates in ENGL 100 and ENGL 110

	Success		Non Success		Withdraw		Total	
	Grades	Percent	Grades	Percent	Grades	Percent	Grades	Percent
ENGL100.	488	67%	144	20%	95	13%	727	100%
ENGL110.	478	70%	119	18 3				

Success Rates in ENGL 1A, 1B, 1C

Note: Success = A, B, C, P; Non Success = D, F, NP, I; Withdraw = W

